

LT1937K	P.1
WHITE LED STEP-UP CONVERTER	

FEATURES

- Inherently Matched LED Current
- High Efficiency: 84% Typical
- Drives Up to Four LEDs from a 3.2V Supply
- Drives Up to Six LEDs from a 5V Supply
- 36V Rugged Bipolar Switch
- Fast 1.2MHz Switching Frequency
- Uses Tiny 1mm Tall Inductors
- Requires Only 0.22 μ F Output Capacitor

APPLICATIONS

- Cellular Phones
- PDAs, Handheld Computers
- Digital Cameras
- MP3 Players
- GPS Receivers

TYPICAL APPLICATION CIRCUIT

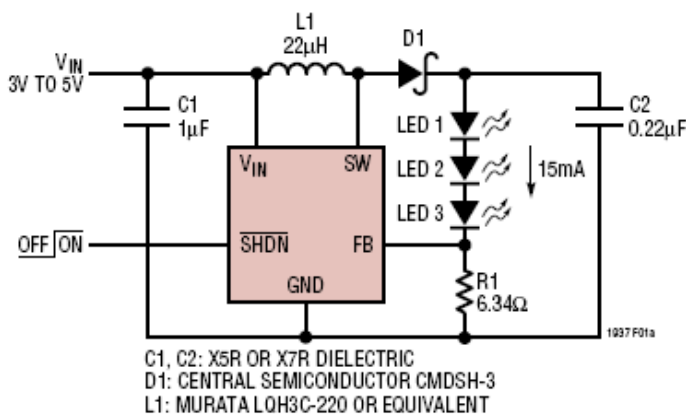
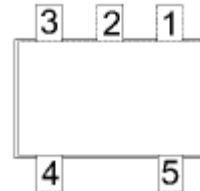

Figure 1. Li-Ion Powered Driver for Three White LEDs

DESCRIPTION

The LT1937K is a step-up DC/DC converter specifically designed to drive white LEDs with a constant current. The device can drive two, three or four LEDs in series from a Li-Ion cell. Series connection of the LEDs provides identical LED currents resulting in uniform brightness and eliminating the need for ballast resistors. The output capacitor can be as small as 0.22 μ F, saving space versus alternative solutions. A low 95mV feedback voltage minimizes power loss for better efficiency.

TOP VIEW



Conversion Efficiency

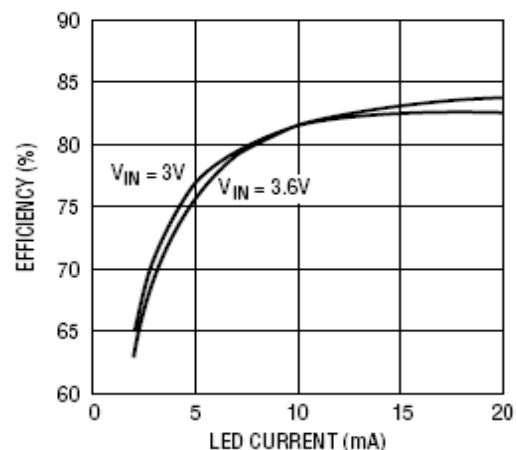

ABSOLUTE MAXIMUM RATINGS (Note1)

Input Voltage (V_{IN})	10V	Operating Temperature Range	0°C to 70°C
SW Voltage	36V	Maximum Junction Temperature	125°C
FB Voltage	10V	Storage Temperature Range	-65°C to 150°C
SHDN Voltage	10V	Lead Temperature (Soldering, 10 sec)	300°C

Note 1: Absolute Maximum Ratings are those values beyond which the life of the device may be impaired.

**WHITE LED STEP-UP
CONVERTER**

PIN FUNCTION

PIN	PIN NAME	PIN DESCRIPTION
1	SW	Switch Pin. (Minimize trace area at this pin to reduce EMI)
2	GND	Ground Pin. Connect directly to local ground plane.
3	FB	Feedback Pin. Reference voltage is 95mV. (Calculate resistor value according to the formula: $R_{FB}=95mV/I_{LED}$.)
4	\overline{SHDN}	Shutdown Pin. (Connect to 1.5V or higher to enable device; 0.4V or less to disable device.)
5	V _{IN}	Input Supply Pin. (Must be locally bypassed.)

ELECTRICAL CHARACTERISTICS T_A=25°C, V_{IN} =3V, V \overline{SHDN} =3V, unless otherwise noted.

PARAMETER	CONDITION	MIN.	TYP.	MAX.	UNIT
Minimum Operating Voltage		2.5			V
Maximum Operating Voltage				10	V
Feedback Voltage	I _{sw} =100mA, Duty Cycle=66%	86	95	104	mV
FB Pin Bias Current		10	45	100	nA
Supply Current	\overline{SHDN} =0V		1.9 0.1	2.5 1.0	mA μ A
Switching Frequency		0.8	1.2	1.6	MHz
Maximum Duty Cycle		85	90		%
Switch Current Limit			320		mA
Switch V _{CESAT}	I _{sw} =250mA		350		mV
Switch Leakage Current	V _{sw} =5V		0.01	5	μ A
\overline{SHDN} Voltage High		1.5			V
\overline{SHDN} Voltage Low				0.4	V
\overline{SHDN} Pin Bias Current			65		μ A

BLOCK DIAGRAM LT1937K (Figure 2.)

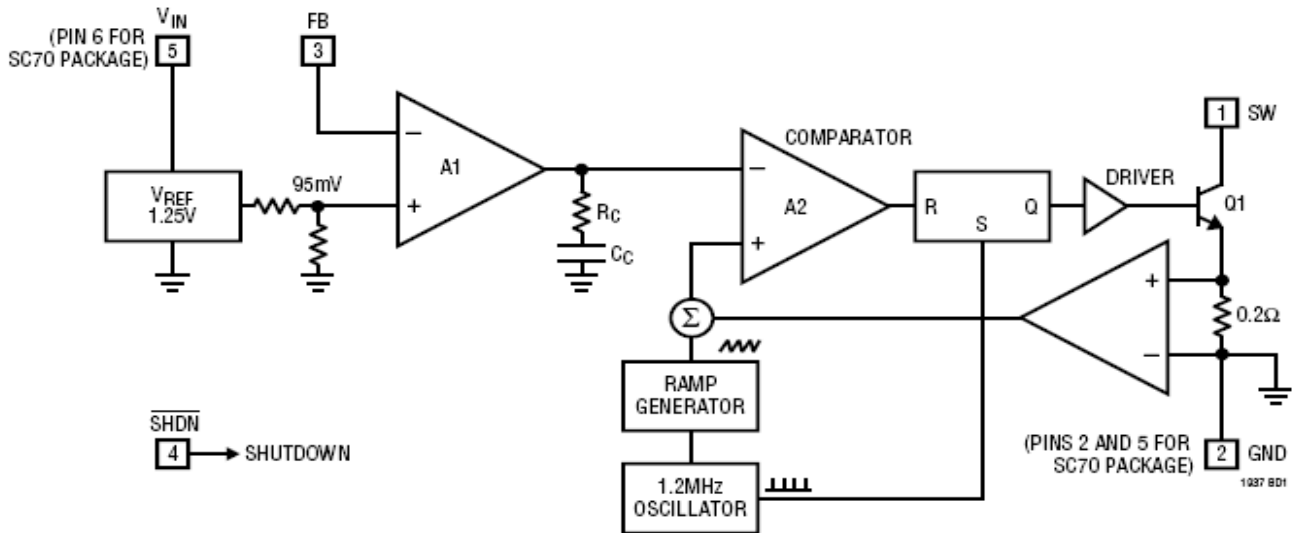

OPERATION

The LT1937K uses a constant frequency, current mode control scheme to provide excellent line and load regulation. Operation can be best understood by referring to the block diagram in Figure 2. At the start of each oscillator cycle, the SR latch is set, which turns on the power switch Q1. A voltage proportional to the switch current is added to a stabilizing ramp and the resulting sum is fed into the positive terminal of the PWM comparator A2. When this voltage exceeds the level at the negative input of A2, the SR latch is reset turning off the power switch. The level at the negative input of A2 is set by the error amplifier A1, and is simply an amplified version of the difference between the feedback voltage and the reference voltage of 95mV. In this manner, the error amplifier sets the correct peak current level to keep the output in regulation. If the error amplifier's output increases, more current is delivered to the output; if it decreases, less current is delivered.

Minimum Output Current

The LT1937K can regulate three series LEDs connected at low output currents, down to approximately 4mA from a 4.2V supply, without pulse skipping, using the same external components as specified for 15mA operation. As current is further reduced, the device will begin skipping pulses. This will result in some low frequency ripple, although the LED current remains regulated on an average basis down to zero.

APPLICATIONS INFORMATION

Inductor Selection

A 22mH inductor is recommended for most LT1937K applications. Although small size and high efficiency are major concerns, the inductor should have low core losses at 1.2MHz and low DCR (copper wire resistance). Some inductors in

**WHITE LED STEP-UP
CONVERTER**

this category with small size are listed in Table 1.

Table 1. Recommended Inductors

PART NUMBER	DCR (Ω)	CURRENT RATING (mA)	MANUFACTURER
LQH3C220	0.71	250	Murata
ELJPC220KF	4.0	160	Panasonic
CDRH3D16-220	0.53	350	Sumida
LB2012B220M	1.7	75	Taiyo Yuden
LEM2520-220	5.5	125	Taiyo Yuden

Capacitor Selection

The small size of ceramic capacitors makes them ideal for LT1937K applications. X5R and X7R types are recommended because they retain their capacitance over wider voltage and temperature ranges than other types such as Y5V or Z5U. A

1 μ F input capacitor and a 0.22 μ F output capacitor are sufficient for most LT1937K applications. Recommended Ceramic Capacitor Manufacturers: Taiyo Yuden, AVX Murata, Kemet.

Diode Selection

Schottky diodes, with their low forward voltage drop and fast reverse recovery, are the ideal choices for LT1937K applications. The forward voltage drop of a Schottky diode represents the conduction losses in the diode, while the diode capacitance (C_T

or C_D) represents the switching losses. For diode selectin, both forward voltage drop and diode capacitance need to be considered. Schottky diodes with higher current ratings usually have lower forward voltage drop and larger diode capacitance, which can cause significant switching losses at the 1.2MHz switching frequency of the LT1937K. A Schottky diode rated at 100mA to 200mA is sufficient for most LT1937K applications. Some recommended Schottky diodes are listed in Table 2.

Table 2. Recommended Schottky Diodes

PART NUMBER	FORWARD CURRENT (mA)	VOLTAGE DROP (V)	DIODE CAPACITANCE (Pf)	MANUFACTURER
CMDSH-3	100	0.58 at 100mA	7.0 at 10V	Central
CMDSH2-3	100	0.49 at 200mA	15 at 10V	Central
BAT54	200	0.53 at 100mA	10 at 25V	Zetex

LT1937K	P.5
WHITE LED STEP-UP CONVERTER	

LED Current Control

The LED current is controlled by the feedback resistor (R1 in Figure 1). The feedback reference is 95mV. The LED current is 95mV/R1. In order to have accurate LED current, precision resistors are preferred (1% is recommended). The formula and table 3 for R1 selection are shown below. $R1=95mV/I_{LED}$.

Table 3. R1 Resistor Value Selection

I_{LED} (mA)	R1 (Ω)
5	19.1
10	9.53
12	7.87
15	6.34
20	4.75

Open-Circuit Protection

In the cases of output open circuit, when the LEDs are disconnected from the circuit or the LEDs fail, the feedback voltage will be zero. The LT1937K will then switch at a high duty cycle resulting in a high output voltage, which may cause the SW pin voltage to exceed its maximum 36V rating. A zener diode can be used at the output to limit the voltage on the SW pin (Figure 3). The zener voltage should be larger than the maximum forward voltage of the LED string. The current rating of the zener should be larger than 0.1mA.

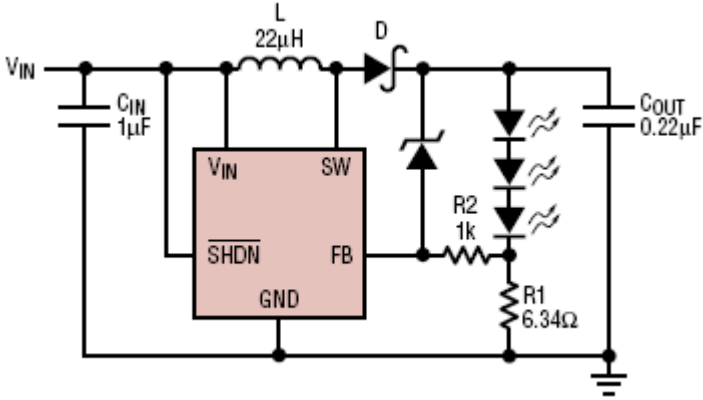

Figure 3. LED Driver with Open-Circuit Protection

Dimming Control

There are some different types of dimming control circuits:

1. Using a PWM Signal to \overline{SHDN} Pin

With the PWM signal applied to the \overline{SHDN} pin, the LT1937K is turned on or off by the PWM signal. The LEDs operate at either zero or full current. The average LED current increases proportionally with the duty cycle of the PWM signal. A 0% duty cycle will turn off the LT1937K and corresponds to zero LED current. A 100% duty cycle corresponds to full current. The typical frequency range of the PWM signal is 1kHz to 10kHz. The magnitude of the PWM signal should be higher than the minimum \overline{SHDN} voltage high.

2. Using a DC voltage

For some applications, the preferred method of brightness control is a variable DC voltage to adjust the LED current. The dimming control using a DC voltage is shown in Figure 4. As the DC voltage increases, the voltage drop on R2 increases and the voltage drop on R1 decreases. Thus, the LED

current decreases. The selection of R2 and R3 will make the current from the variable DC source much smaller than the LED current and much larger than the FB pin bias current. For V_{DC} range from 0V to 2V, the selection of resistors in Figure 4 gives dimming control of LED current from 0mA to 15mA.

1. Using a Filtered PWM Signal

The filtered PWM signal can be considered as an adjustable DC voltage. It can be used to replace the variable DC voltage source in dimming control. The circuit is shown in Figure 5.

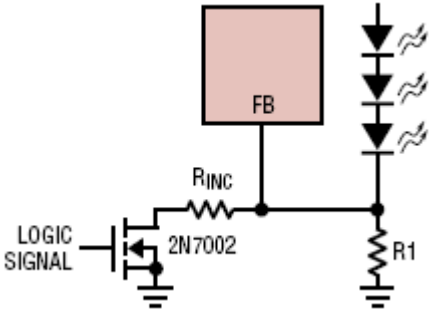

Figure 5. Dimming Control Using a Filtered PWM Signal

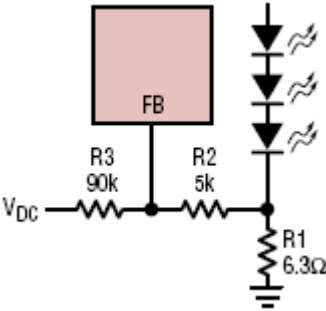

Figure 4. Dimming Control Using a DC Voltage